

A	1
B	2
C	3
D	4
E	5
F	6
H	7
J	8
K	9
L	10
M	11
N	12
P	13
R	14
S	15
T	16
U	17
V	18
AA	21
BB	22
CC	23
DD	24
EE	25
FF	26
HH	27
JJ	28
KK	29
LL	30
MM	31
NN	32
PP	33
RR	34
SS	35
TT	36
UU	37
VV	38

A	1
B	2
C	3
D	4
E	5
F	6
H	7
J	8
K	9
L	10
M	11
N	12
P	13
R	14
S	15
T	16
U	17
V	18
AA	21
BB	22
CC	23
DD	24
EE	25
FF	26
HH	27
JJ	28
KK	29
LL	30
MM	31
NN	32
PP	33
RR	34
SS	35
TT	36
UU	37
VV	38

Reverse-engineered schematics for the Burroughs IPT-7050
 This main page represents the wire-wrap backplane.

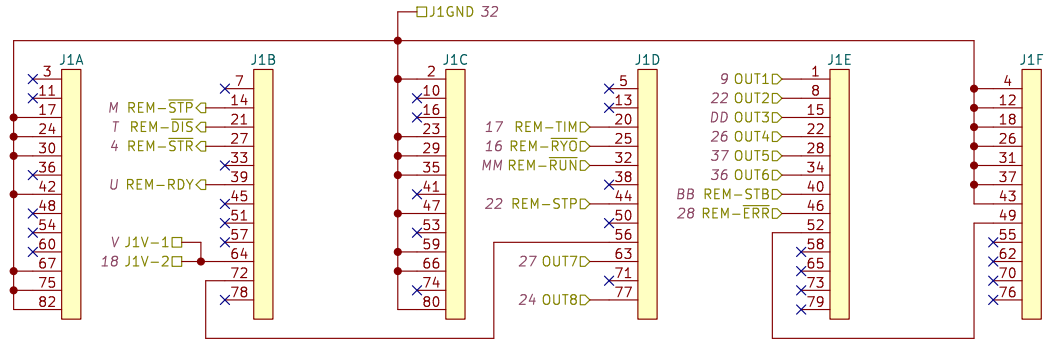
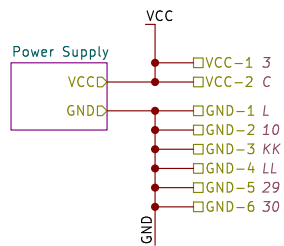
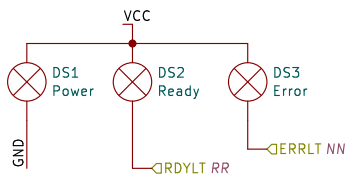
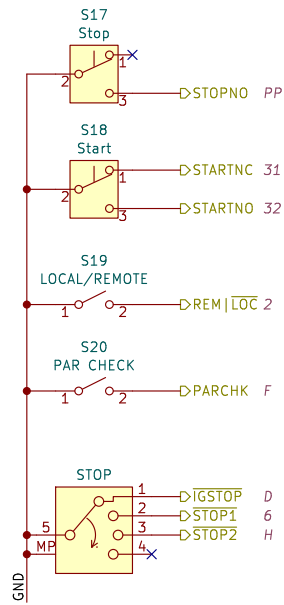
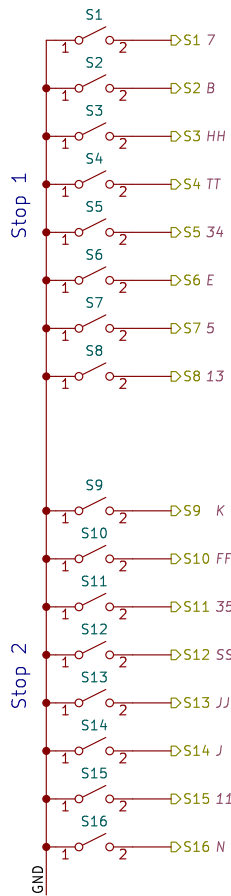

Inputs from Remote:

- RY0 Indicates that the remote device is ready.
- DIS When DIS goes low, the ready latch is cleared.
- STR Start reader; equivalent to pressing local start button.
- STP Stop reader; equivalent to pressing local stop button.

Outputs to Remote:

- RY0 The controller, drive, and remote device are ready.
- RUN Low when the drive is running.
- STP A high pulse means the drive was stopped.
- STB A data character is ready on OUT1..8.
- ERR Indicates that a parity error occurred.
- TIM Indicates that the controller timed out; the tape is probably broken.

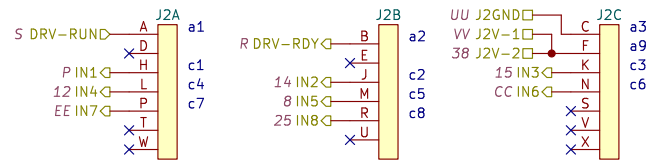

RUN Output to drive telling it to run
RDY Input from drive indicating that it is ready

This board connects the front panel and rear connectors to the backplane and the rest of the boards.

Wiring Harness Connector

Date: 2024-03-05

Rev: 1

Id: 2/8

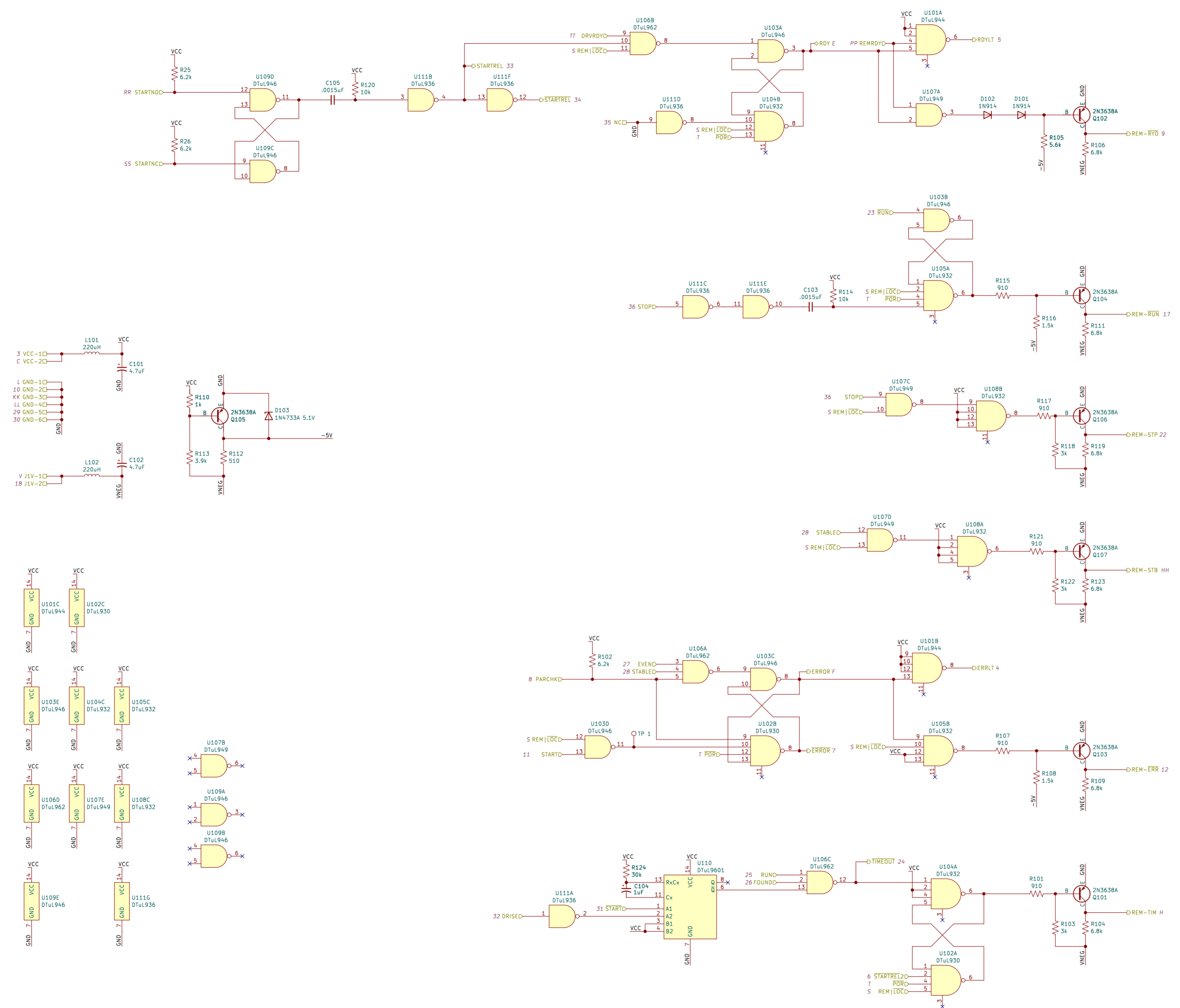

This board consists primarily of the outputs to the remote device, but some of the logic is also used by other parts of the machine.

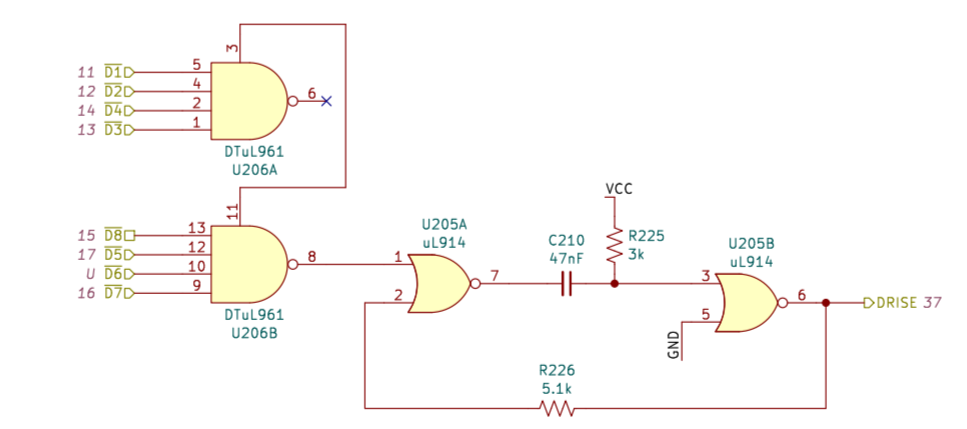
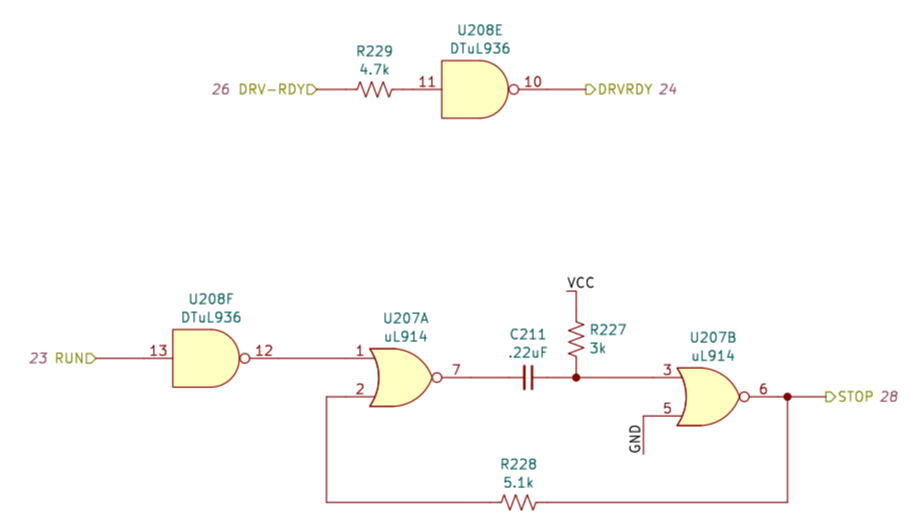
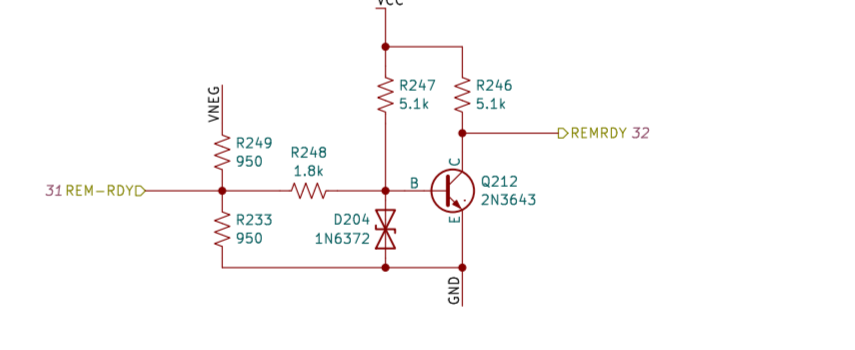
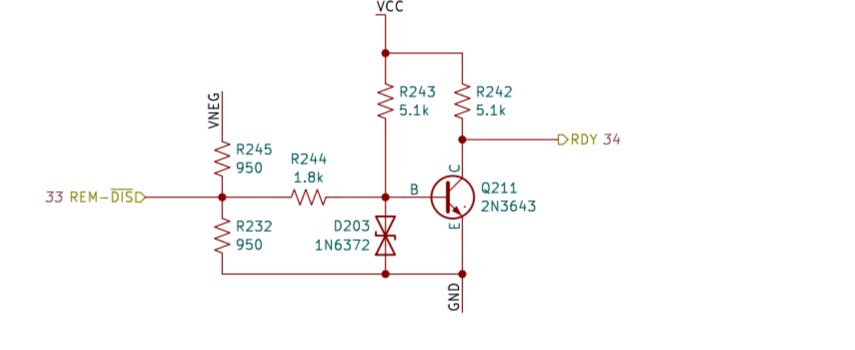
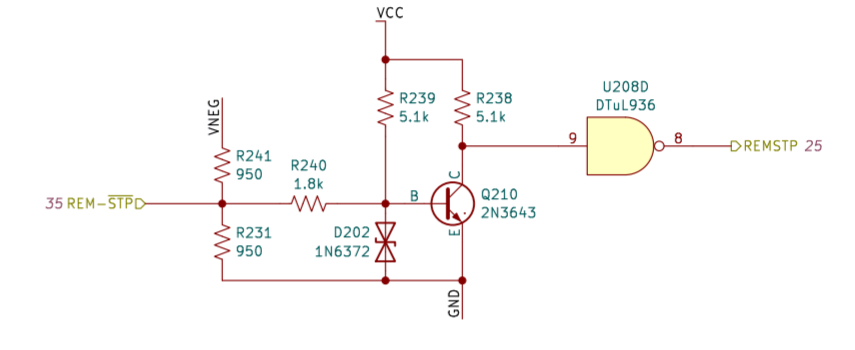
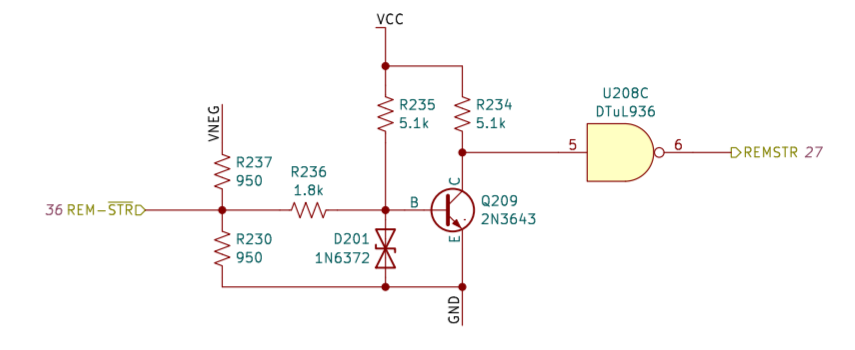
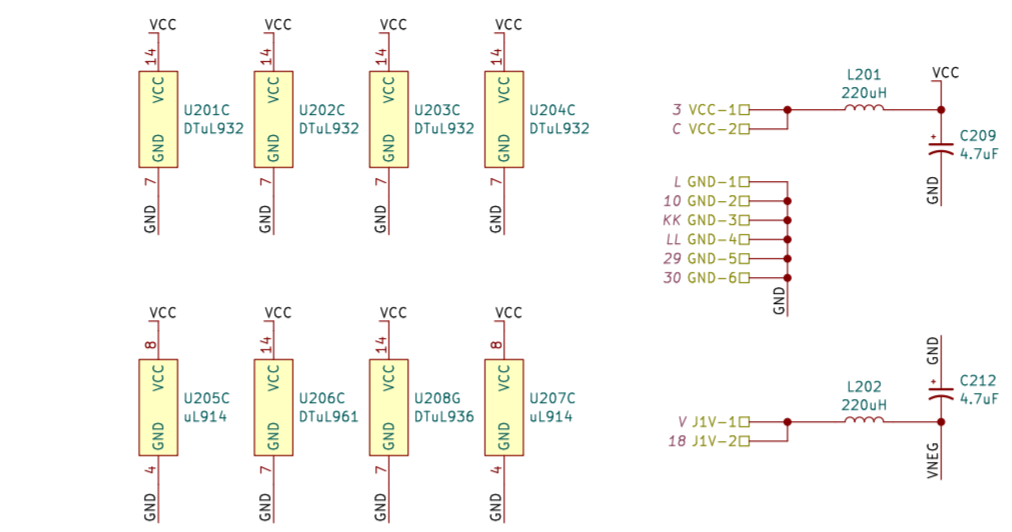
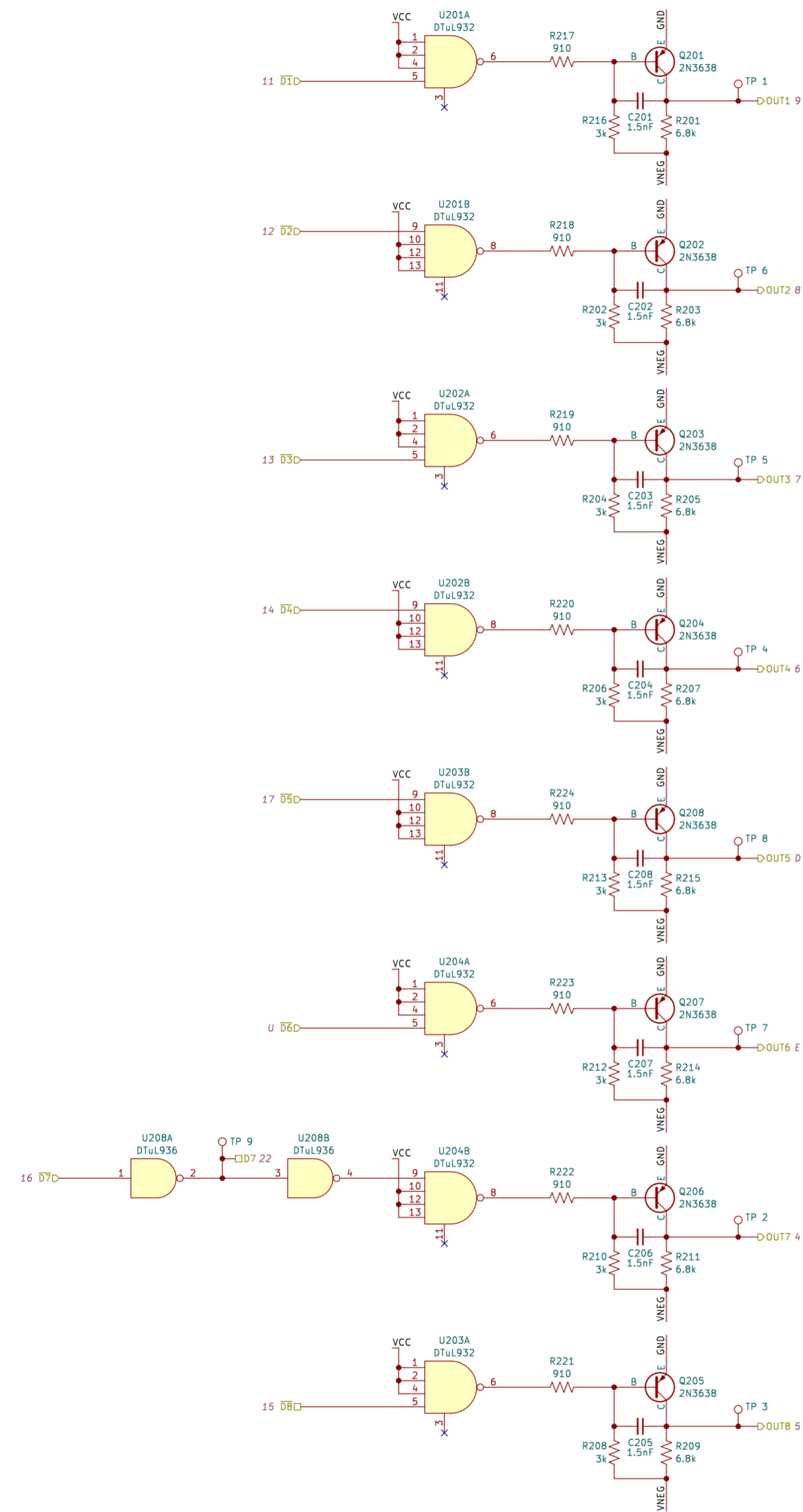

This board translates the control inputs from the remote device and the data outputs to the remote device. It also contains some random logic.

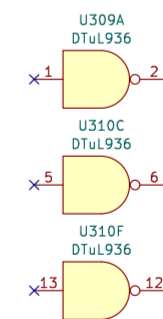
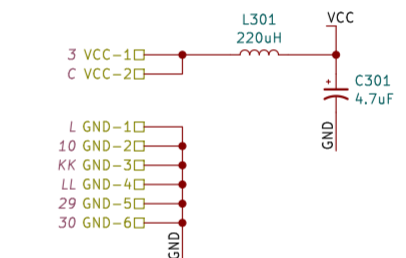
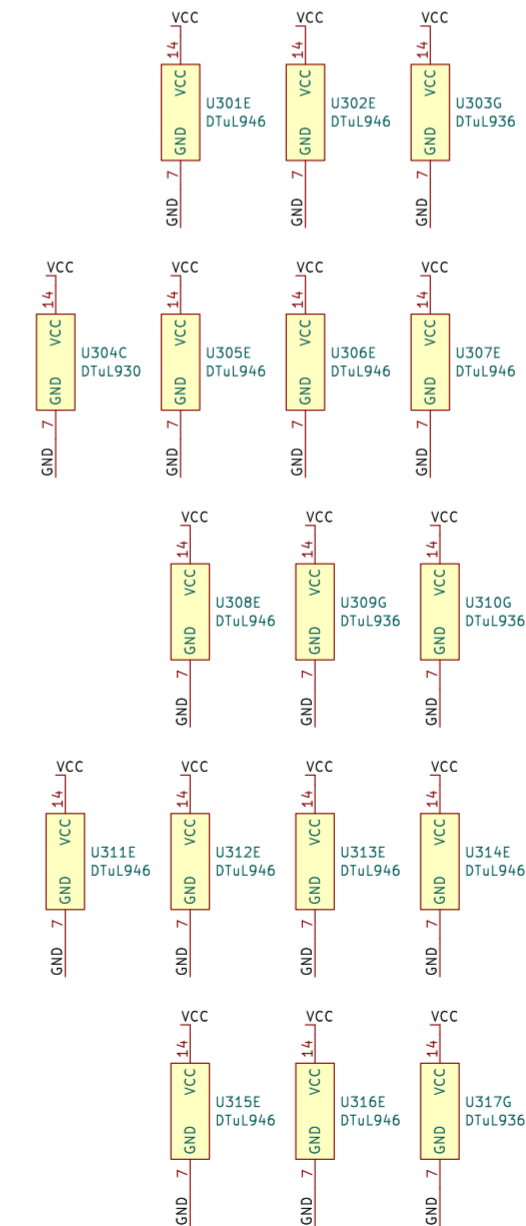
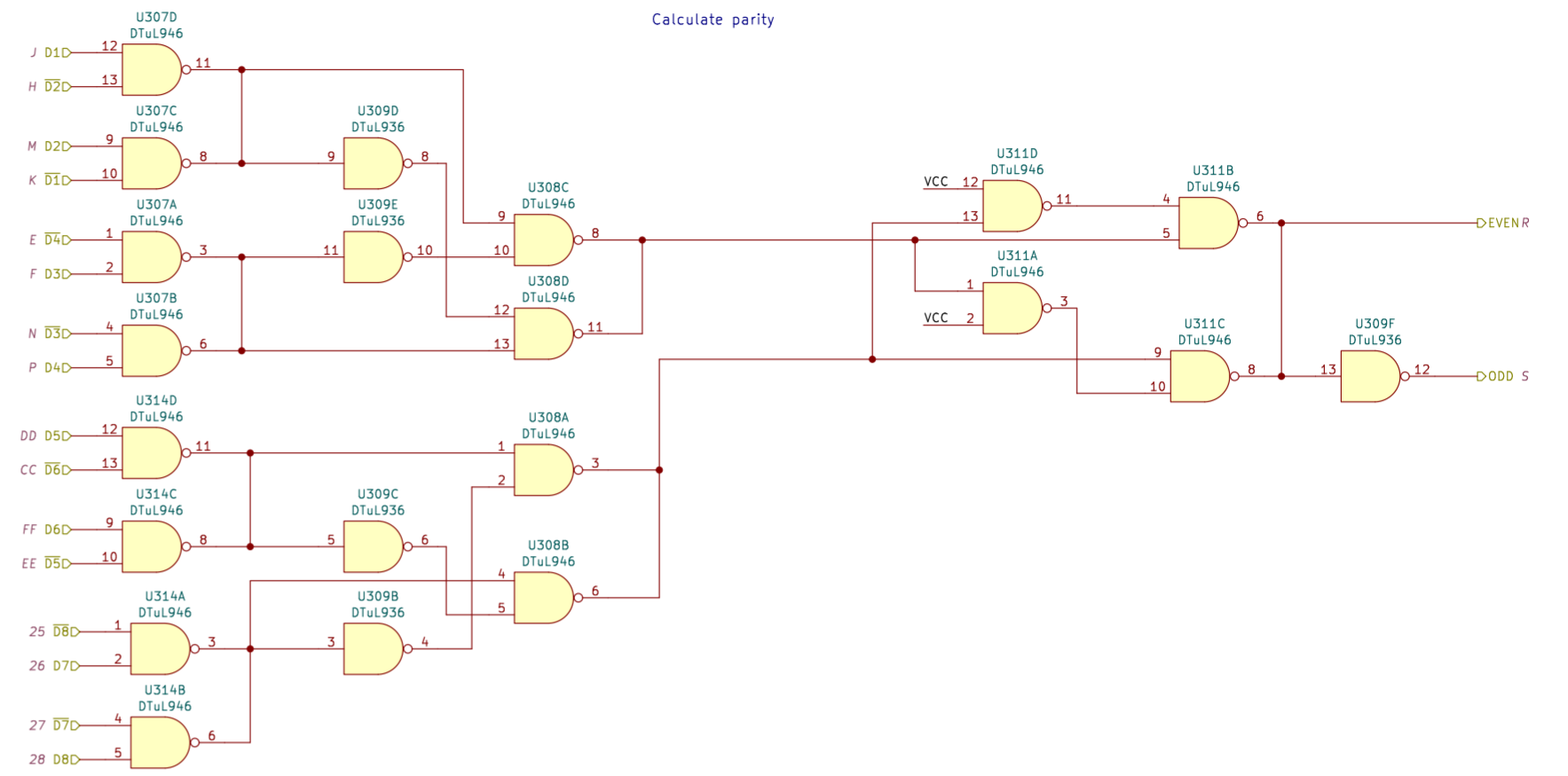
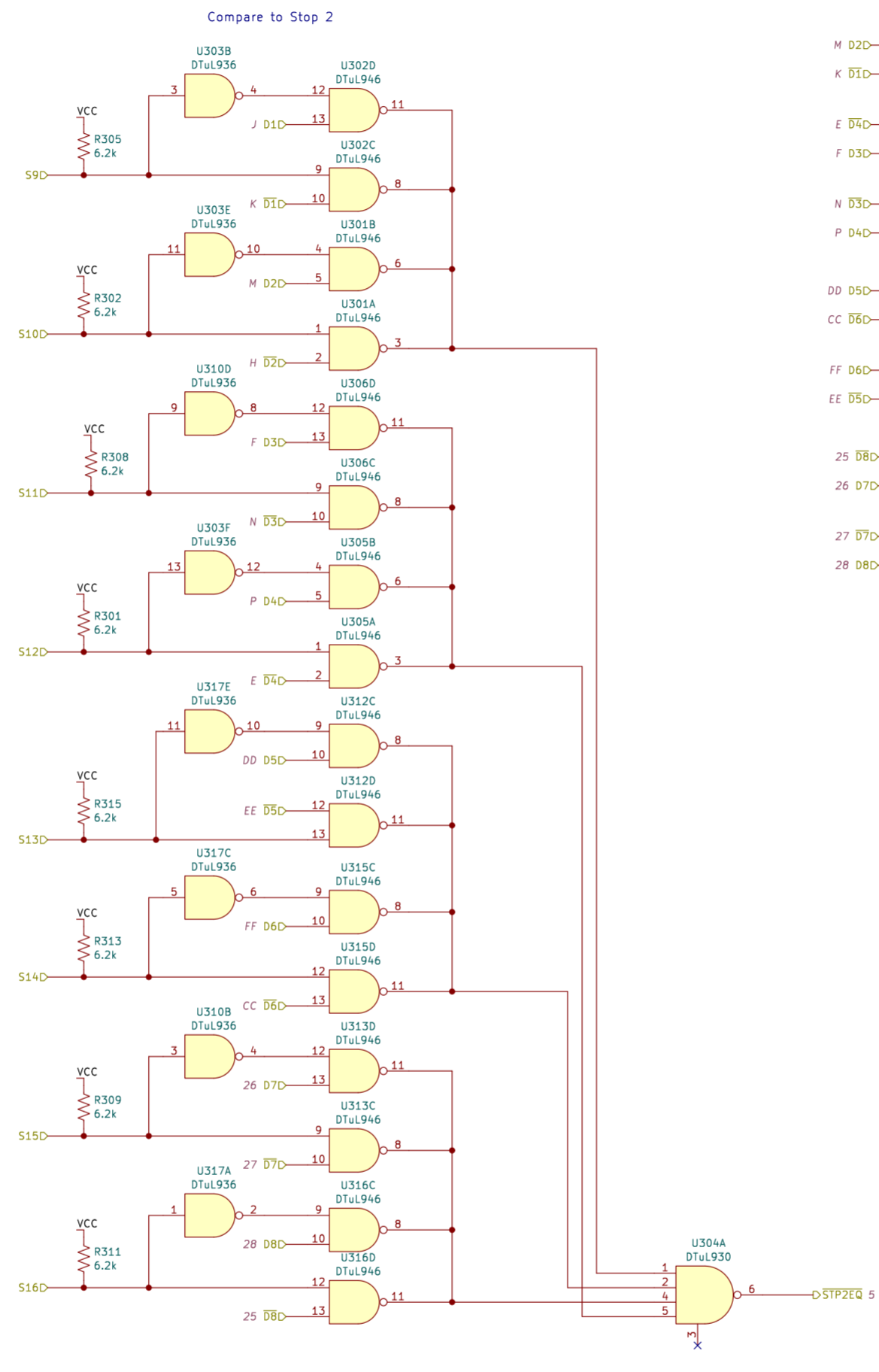
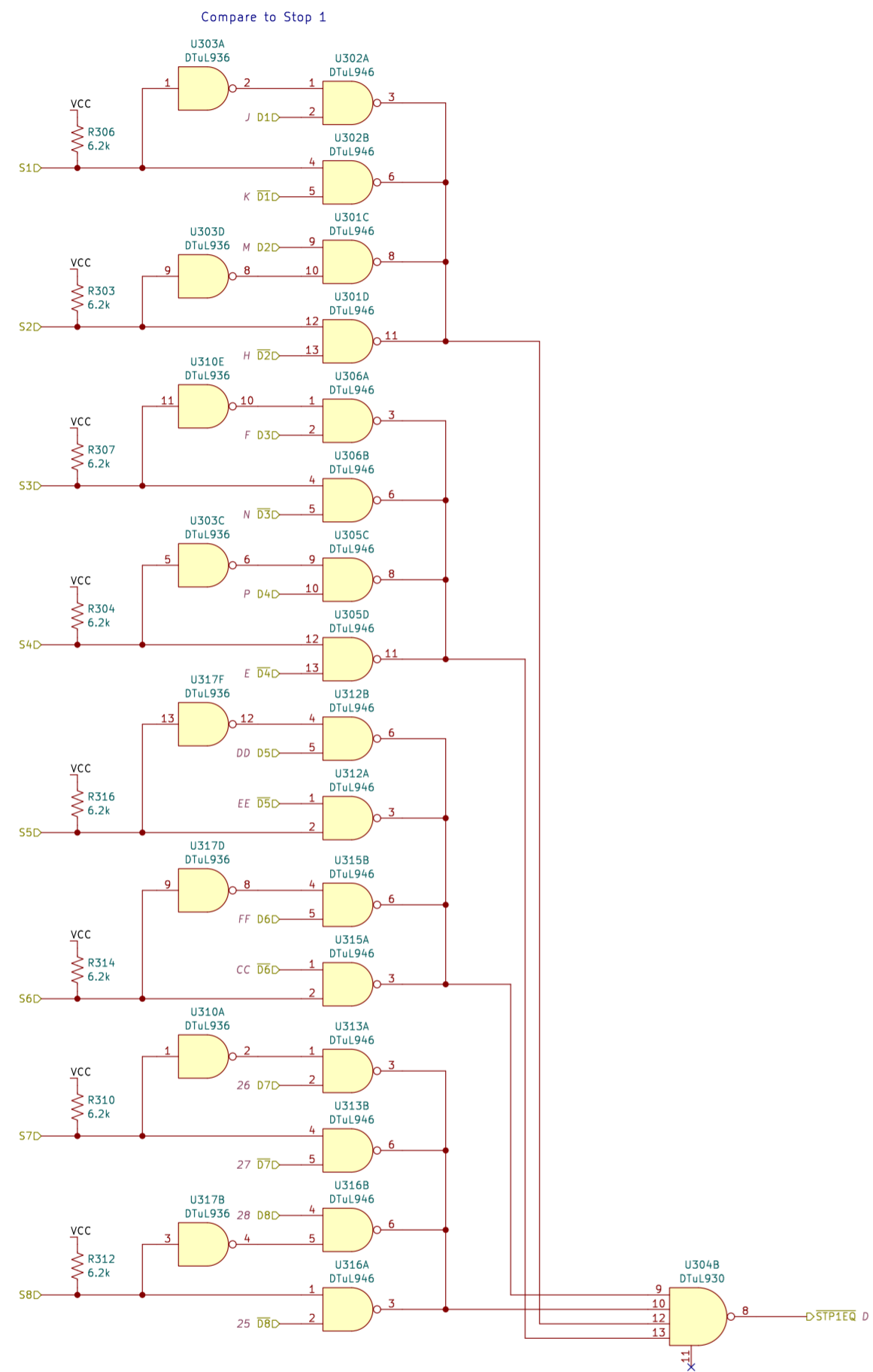

This board compares the data input against the two stop characters and calculates the parity.

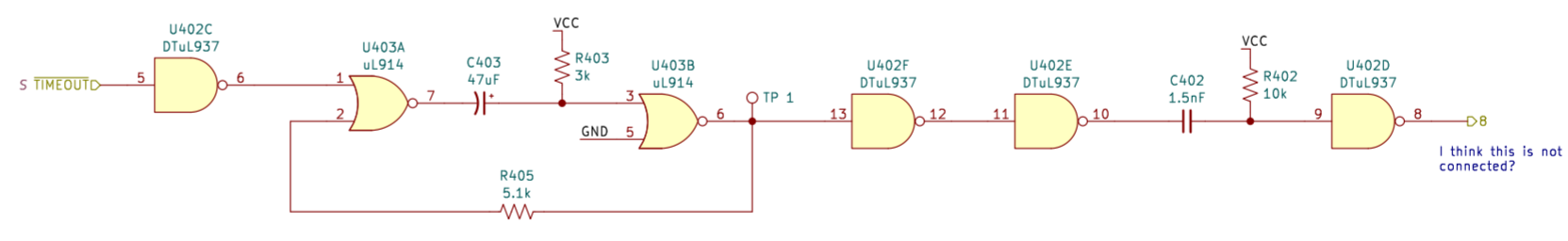
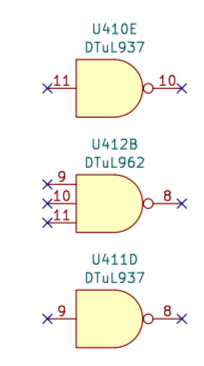
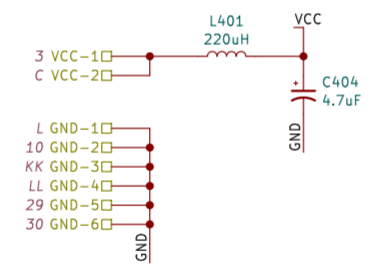
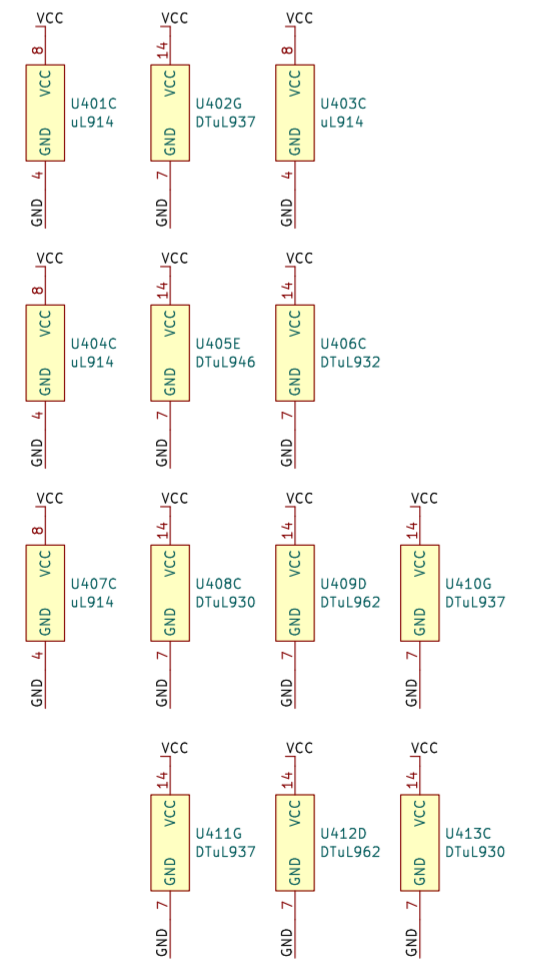
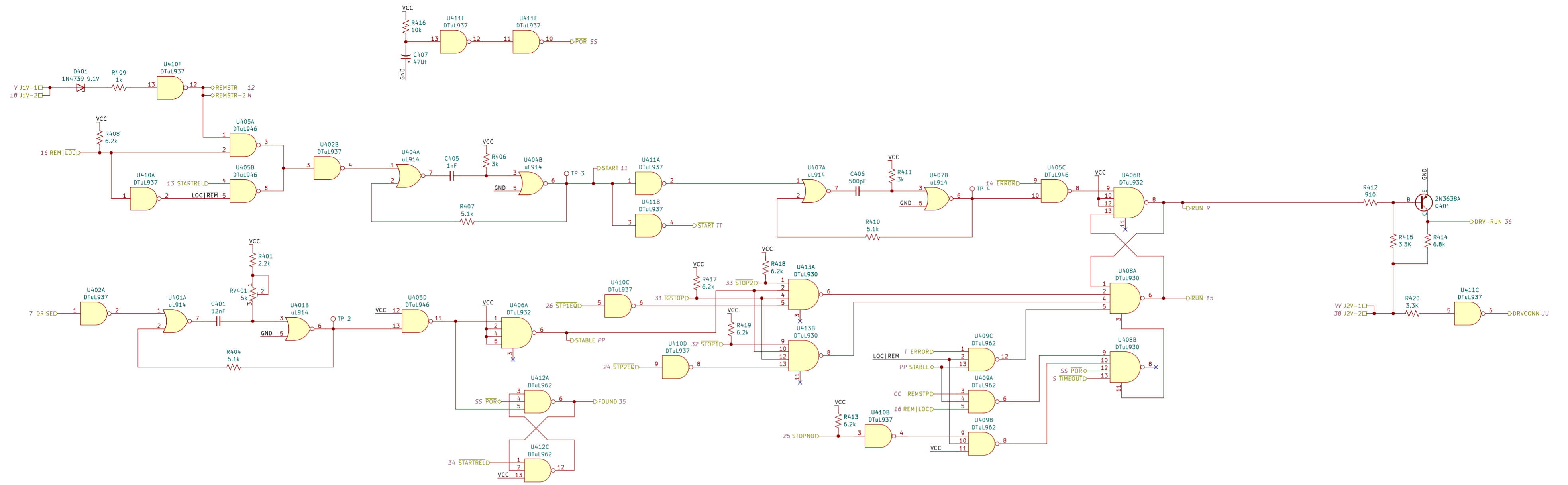

This board contains the main control logic to determine, among other things, when the drive should run.

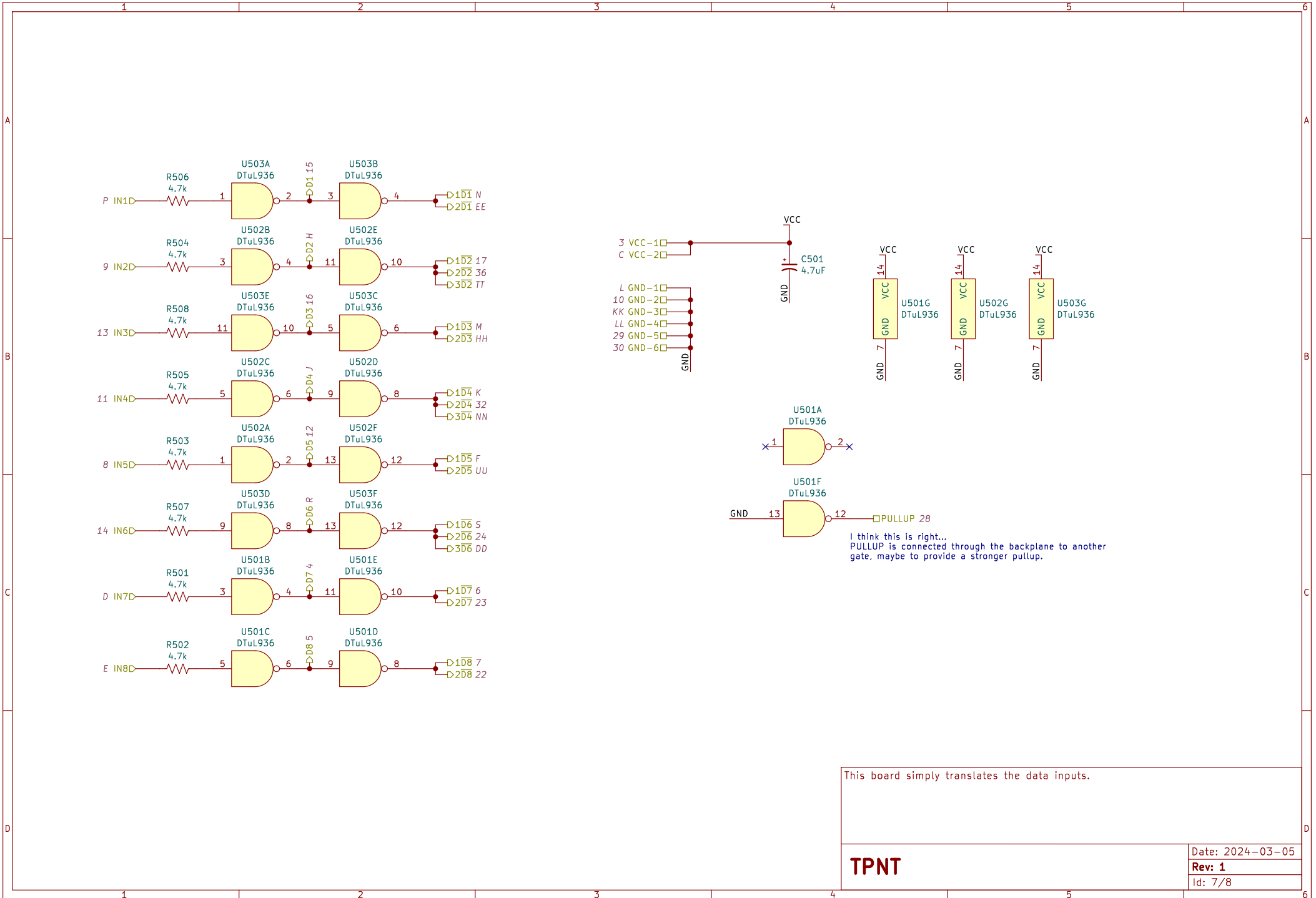

This board simply translates the data inputs.

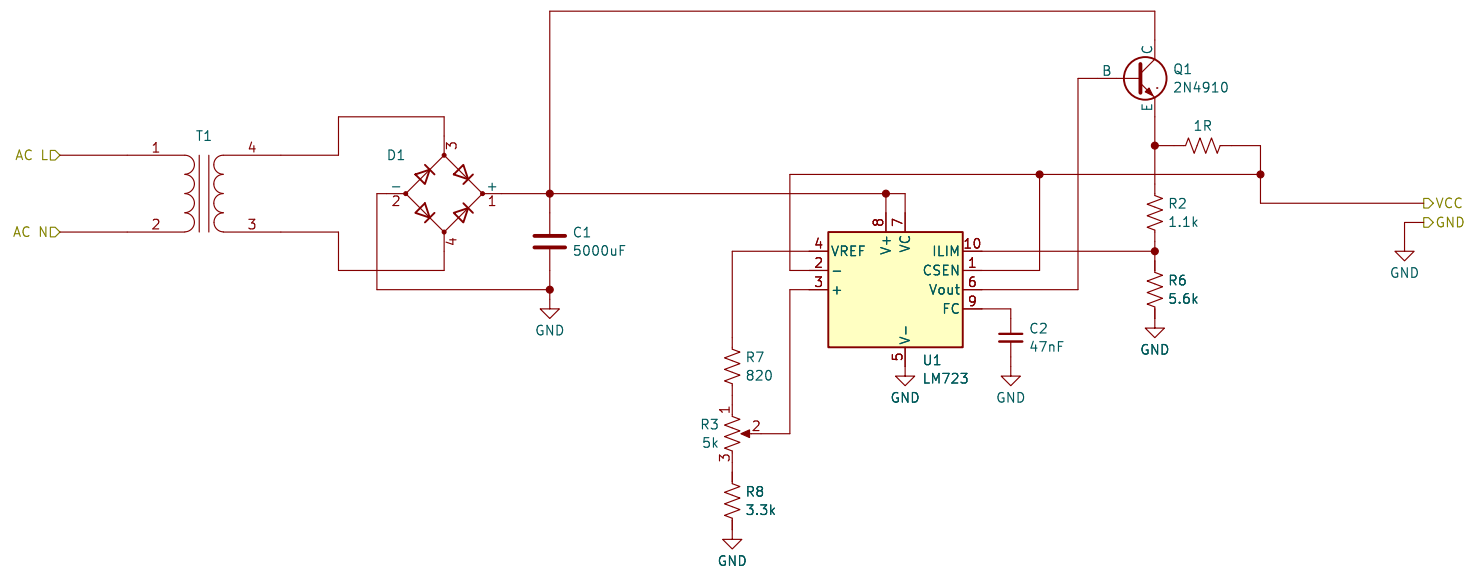

Simple 5V regulator

Power Supply

Date: 2024-03-05

Rev: 1

Id: 8/8